



# LC2000 & LC4000

## Linear Frame-rate Converter

The LC2000 and LC4000 are highly cost-effective, linear motion adaptive frame-rate converters.

### Key Features

- Linear motion adaptive SD/HD/3G frame-rate conversion
- Independent dual-channel (LC2000) and quad-channel conversion (LC4000)
- SD/HD/3G up/down/crossconversion
- Flexible video and audio I/O configuration
- 16-channel embedded audio processing for each video channel
- Continuous output when input standard switches
- HDMI monitor output
- Dual PSU as standard
- Relay bypass on primary SDI inputs
- Automatic aspect ratio conversion (AFD, VI, L23)
- Powerful picture enhancement tools
- Front panel and remote control via GV Orbit
- Closed caption and timecode handling
- Synchronization
- User chosen line for SMPTE ST 2016
- GPI support
- Front panel control lock
- Caption generator
- Logo inserter
- Sidebar keyer
- Clean cut
- Composite input/output
- Fiber input/output

### Applications

- High-density international program distribution
- Low-cost frame-rate conversion
- International TV and video backup channels

### LC2000/4000 Front Panel

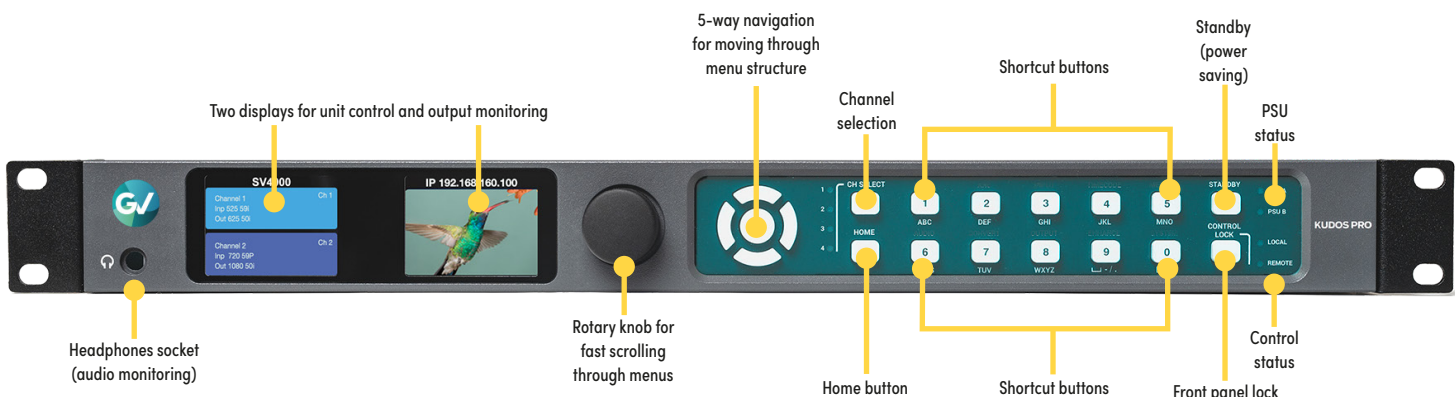

## LC2000 Video Processing

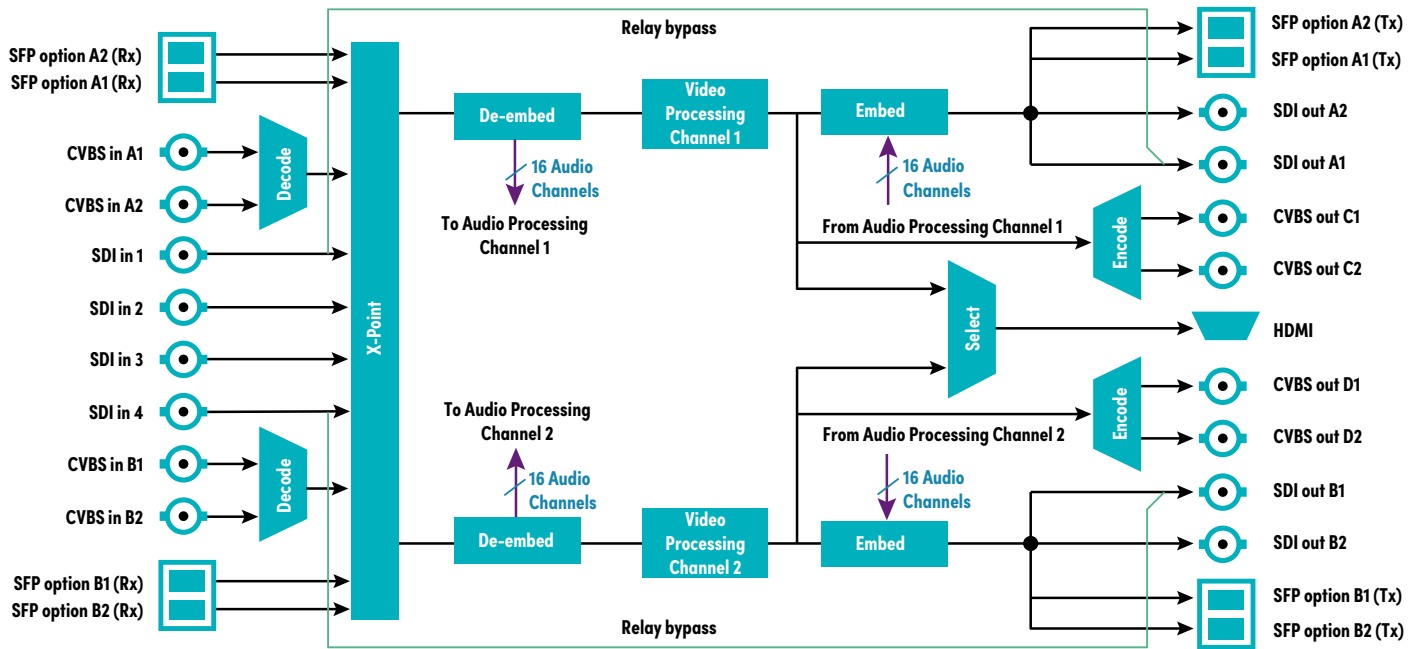

## LC4000 Video Processing

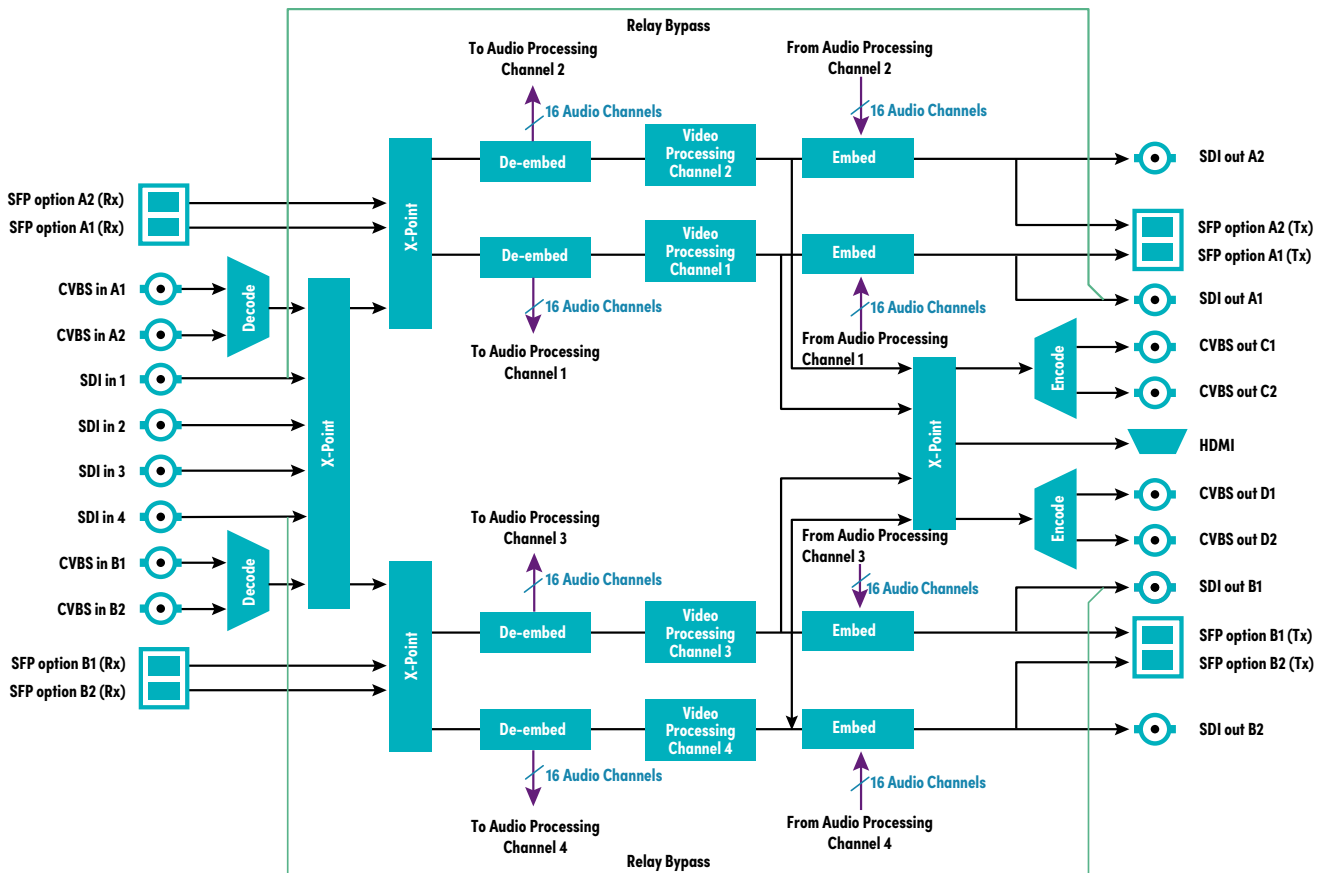

## LC2000 Audio Processing

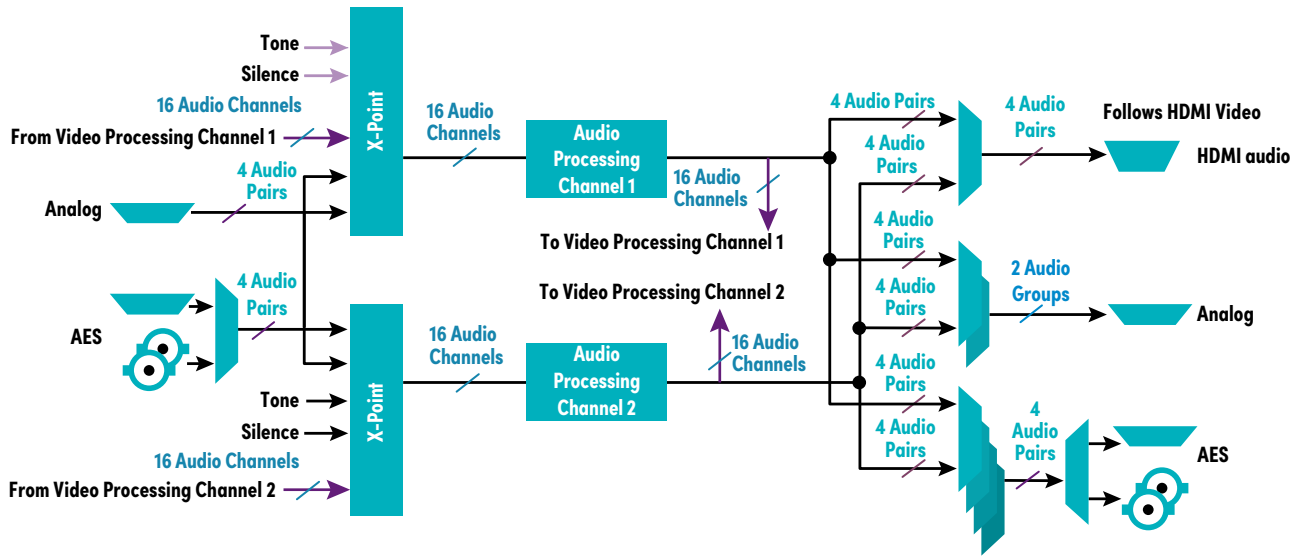

## LC4000 Audio Processing

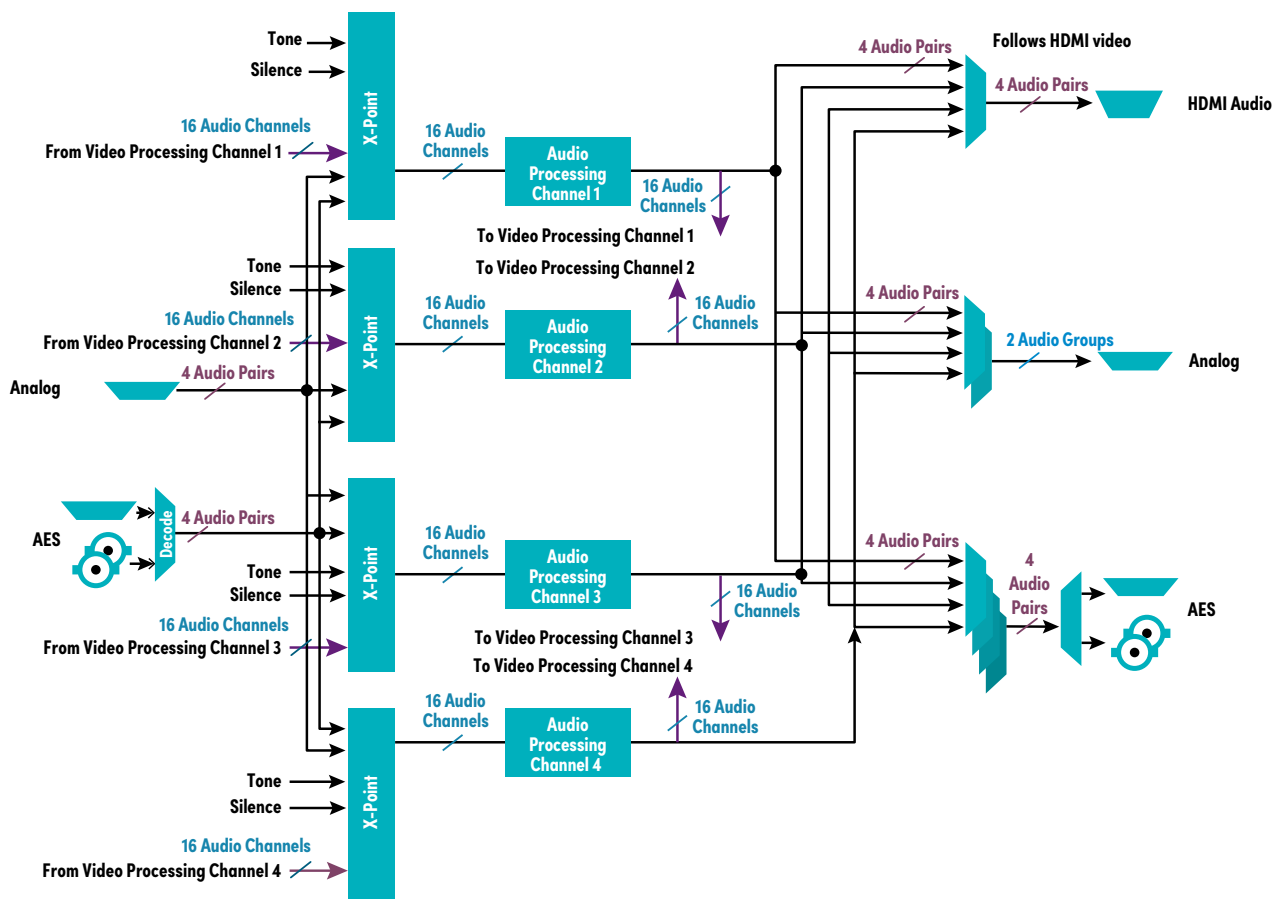

## LC2000/4000 Rear Panel

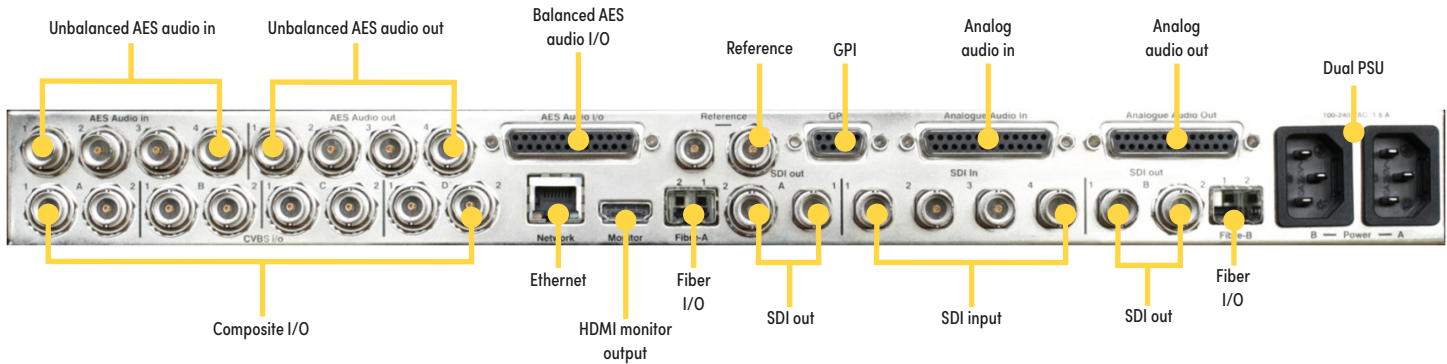

## Specifications

### Signal Inputs

Serial digital 4x 75Ω SD/HD/3G serial digital with embedded audio

#### Input standards:

- 3 Gb/s SD-SDI, SMPTE ST 425 level A, level B
- 1.5 Gb/s HD-SDI SMPTE ST 292/SMPTE ST 299
- 270 Mb/s SD-SDI SMPTE ST 259

Composite PAL, NTSC, NTSC-J, PAL-M, PAL-N, N4.4, SECAM

12-bit ADCs

Analog component YC

**Reference:** 1x loop-through HDTV Tri-sync/SD Bi-sync (blackburst) SMPTE ST 240/SMPTE ST 274

#### Audio AES:

- 4x balanced AES inputs – via 25-way D-type
- 4x unbalanced AES inputs – via 4x BNC

**Audio analog:** 4x stereo analog inputs via 25-way D-type

### Signal Outputs

Serial digital 4x 75Ω SD/HD/3G serial digital with embedded audio

#### Output standards:

- 3 Gb/s HD-SDI, SMPTE ST 425 level A, level B
- 1.5 Gb/s HD-SDI SMPTE ST 292/SMPTE ST 299
- 270 Mb/s SD-SDI SMPTE ST 259

Composite PAL, NTSC, NTSC-J, PAL-M, PAL-N

12-bit DACs

Analog component YC

#### Audio AES:

- 4x balanced AES outputs – via 25-way D-type
- 4x unbalanced AES outputs – via 4x BNC

**Audio analog:** 2x stereo analog outputs via 25-way D-type

### Input Standards

(auto detect) 525, 625

720 50/59.94/60p

1080 50/59.94/60i

1080 50/59.94/60p (Levels A and B)

720/1080 23.98/24/25/29/30p

1080 23.98/24/25/29.97/30PsF, with film detection and processing

### Output Standards

525, 625

720 50/59.94/60p

1080 50/59.94/60i

1080 50/59.94/60p (Levels A and B)

720/1080 23.98/24/25/29/30p

1080 23.98/24/25/29.97/30PsF, with film detection and processing

### Conversion Functions

#### Modes:

SD/HD/3G linear frame rate

Up/down/crossconversion

Frame Synchronizer

**Conversion:** Up/down/crossconversion

### Manual or Automatic ARC

AFD (SMPTE ST 2016), VI (RP186), WSS (L23)

**SD input format:** Normal 4:3, Anamorphic 16:9, Letterbox 14:9, Letterbox 16:9

**SD output format:** Normal 4:3, Anamorphic 16:9, Letterbox 14:9, Letterbox 16:9

**Auto zoom:** On/Off

**Manual zoom:** Zoom ±20%

**Safe area marker:** Off, 16:9, 4:3

**Manual controls:** Size, aspect, pan, tilt

Wide range of ARC presets including 702 sample line mode

### Audio Functions

#### Analog Audio:

Four pairs of analog inputs are individually available to any or all processing channels

Two groups (2 pairs) of analog output are separately assignable to any processing channel

Headroom +24 dBu; balanced connection

#### AES Audio:

Four AES audio inputs are individually available to any or all processing channels

Four AES audio outputs (48 kHz) are separately assignable to any processing channel

AES input is auto-detected as PCM (32-96 kHz) or non-PCM (48 kHz locked to relevant video input)

#### Embedded Audio:

Each processing channel includes 16-channel embedded audio processing

PCM audio processing includes channel level gain and delay compensation, as well as channel level routing/shuffle with audio phase inversion

Non-PCM processing features pair level routing and delay compensation

### Metadata

Closed caption CEA608 <> CEA708

Timecode conversions

WST/SMPTE RDD08/SMPTE ST 2031 conversion

## Specifications (cont.)

### Enhancement

#### Advanced Horizontal Enhancement:

Frequency band selection (Low, Med, High)  
4 preset enhancement levels (Low, Med, High, Super)  
Custom H Gain and H Noise rejection levels

#### Advanced Vertical Enhancement:

Frequency band selection (Low, Med, High)  
5 preset enhancement levels (Soft 2, Soft 1, Normal, Sharp 1, Sharp 2)

#### Horizontal Aperture:

5 preset H sharpness levels (Low 2, Low 1, Normal, High 1, High 2)  
5 preset H detail levels (Soft 2, Soft 1, Normal, Sharp 1, Sharp 2)

#### Noise reduction: Spatial, recursive

**Y/C alignment:** Corrects for upstream luma-chroma displacement

### System

Pattern Off, Black, Ramp, Bars

#### Proc amp:

Black Level: +100 to -100 mV (0) in 0.8 mV steps  
Contrast: -6 dB to +6 dB (0) in 0.2 dB steps  
Saturation: -6 dB to +6 dB (0) in 0.2 dB steps  
Y Gamma: 0.4 to 1.7 (1) in 0.1 steps

#### Freeze: On/Off

**Genlock:** Reference lock, Input lock (same format), Follow input (same frame rate), Free run

#### Memories: 16 user memories

Legalizer  
EDH support

### Communications

Remote control via GV Orbit and SNMP

#### Power (Primary and Secondary)

Input voltage range 100 – 240 VAC, 50/60 Hz 1.5A (max.) via three-pin IEC power socket

### Mechanical

**Temperature range:** 0 to 45° C (32° to 113° F) operating

**Cooling:** Internal fan, side venting

**Weight:** Approximately 4.25 kg (9.4 lbs.)

**Case type:** 1 RU, rack mounting

**Dimensions:** 44 x 430 x 400 mm (1.7 x 16.9 x 15.7 in.) (HxWxD)

Headphones socket with volume control

**GPIO:** 8 available

### Throughput Delay

#### Video processing delay:

– **Field = 16.7 or 20 ms**

– **Frame = 33.3 or 40 ms**

With scaling active in same frame rate:

– Ref lock/Free run – between 3 and 5 fields + ~200  $\mu$ s

– Input lock (SDI) – 3 fields + 1 ms

With same standard in & out and Sync mode = Enabled:

– Ref lock/Free run – between ~200  $\mu$ s and 1 frame + ~200  $\mu$ s

– Input lock (SDI) – ~1 ms

Frame-rate conversion:

– Any lock mode – 110 ms typical

#### Audio processing delay (Audio delay = 0 ms):

With scaling active in same frame rate:

– Ref lock/Free run – 1.5 frames

– Input lock – 1 frame + 1 ms

With same standard in & out and sync mode = Enabled:

– Ref lock/Free run – 0.5 frames

– Input lock – ~3 ms

Frame-rate conversion:

– Any lock mode – 110 ms typical

## Ordering

### 6122110

LC2000-CT2 Dual channel video & audio processing unit, including frame-rate/format conversion, frame synchronization, ARC control, noise reduction, side-bar keying, logo insertion, CC, WST and timecode handling, picture enhancement tools, 16 channel audio processing including gain, delay & shuffling. SDI (BNC or fiber), CVBS, GPI, AES and analog audio I/O. HDMI monitor output & dual PSUs.

### 6124110

LC4000-CT2 Quad channel video & audio processing unit, including frame-rate/format conversion, frame synchronization, ARC control, noise reduction, side-bar keying, logo insertion, CC, WST and timecode handling, picture enhancement tools, 16 channel audio processing including gain, delay & shuffling. SDI (BNC or fiber), CVBS for 2 channels, GPI, AES and analog audio I/O. HDMI monitor output & dual PSUs.

### Fiber SFP Options for Fiber – A&B

**FC1-13TR** Transceiver 1310 nm/Rx

**FC1-13T1** Single 1310 nm Tx

**FC1-13T2** Dual 1310 nm Tx

**FC1-R1** Single Rx

**FC1-R2** Dual Rx

**FC1-HDBT2** HD-BNC Dual Tx

**FC1-HDBR2** HD-BNC Dual Rx

Note: Fiber SFP type must be ordered in addition to the unit.

This product may be protected by one or more patents. For further information, please visit: [www.grassvalley.com/patents](http://www.grassvalley.com/patents)

DS-PUB-3-1062B-EN

Grass Valley®, GV®, GV Grass Valley®, and the Grass Valley logo are trademarks or registered trademarks of Grass Valley USA, LLC, or its affiliated companies in the United States and other jurisdictions. Grass Valley products listed above are trademarks or registered trademarks of Grass Valley USA, LLC or its affiliated companies, and other parties may also have trademark rights in other terms used herein. Copyright © 2024 Grass Valley Canada. All rights reserved. Specifications subject to change without notice.

[www.grassvalley.com](http://www.grassvalley.com) Join the Conversation at GrassValleyLive on [Facebook](#), [X](#), [YouTube](#) and Grass Valley on [LinkedIn](#)